

Pentola Indiretta Elettrica

PM7IE050 – PM8IE150

Indirect Electric boiling pan



Pentole indirette elettriche

Vasca di cottura con fondo in AISI 316 specifico per trattare prodotti particolarmente acidi e pareti in AISI 304. Intercapedine in AISI 304. Coperchio bilanciato in AISI 304 dotato di maniglia atermica. Cerniera a baionetta per modelli da 50 lt. Isolamento termico garantito da pannelli in fibra di vetro di grosso spessore.



Indirect electric boiling pans

Cook tank with AISI 316 bottom specifically for particularly acidic products and walls made out of AISI 304. Tub made out of AISI 304. Balanced lid in AISI 304 equipped with heat absorbing handle. Bayonet hinge for 50 lt. models. Thermal insulation ensured by thick fibreglass panels



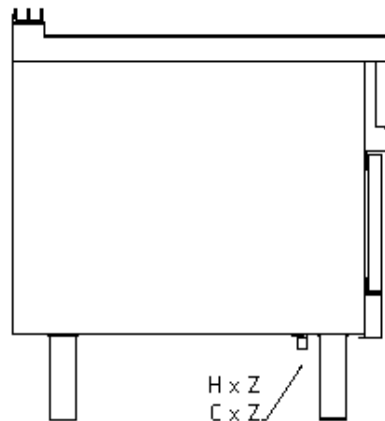
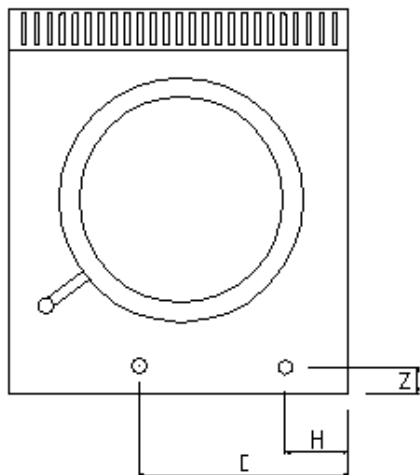

Schema per risalire alla predisposizione delle utenze

PENTOLA INDIRECTA ELETTRICA INDIRECT ELECTRIC BOILING PAN

| CODICE CODE | ALIMENTAZIONE - H x Z POWER | CARICO ACQUA F 1/2" - C x Z WATER LOAD |
|----------------|--------------------------------|---|
| PM7IE050 | 180 X 40 | 580 X 40 |
| PM8IE150 | 180 X 40 | 580 X 40 |

| CODICE CODE | DIMENSIONI (mm.) L X P X H DIMENSIONS (mm.) | KW TOT | VHZ | CAPACITA' CAPACITY |
|----------------|---|--------|--------|-----------------------|
| PM7IE050 | 800x700x900 | 9 | 400\50 | 50 L |
| PM8IE150 | 800x900x900 | 18 | 400\50 | 100 L |

ACCESSORI A RICHIESTA / OPTIONAL ACCESSORIES

| CODICE CODE | DESCRIZIONE DESCRIPTION |
|----------------|---|
| 10500 | CESTELLO INTERNO LT 50 / ENTIRE BASKET LT 50 |
| 10610 | CESTELLO INTERNO LT 150 / ENTIRE BASKET LT 150 |
| 20610 | CESTELLO IN 2 PARTI LT 150 / BASKET IN 2 PARTS LT 150 |
| 30610 | CESTELLO IN 3 PARTI LT 150 / BASKET IN 3 PARTS LT 150 |

FONDO VASCA IN ACCIAIO INOX / STAINLESS STEEL BOTTOM TANK