

Friggitrice a GAS su base armadiata 2 vasche

7CFFG2SI – 9CFFG2SI – 7CFFG2D – 9CFFG2D

GAS fryer on cupboard base 2 tanks



Invaso a passo con scivolo anteriore realizzato tramite stampaggio.
Capacità per singola vasca lt.18.
Disponibile vasca raccogli olio con filtro. La valvola è di tipo meccanico senza necessità di connessione elettrica. Le vasche da lt. 18 e 21 hanno gli scambiatori in vasca per avere la massima potenza in minor tempo. Adatto per alta produttività.
La versione digitale permette di impostare un differenziale di accensione anche di un solo grado per avere una macchina più reattiva. Presente la funzione melting che prevede una temperatura di preriscaldamento e mantenimento per avere la macchina



Recessed basin with sliding front created by moulding.
18lt capacity for a single recess for both gas and electric versions.
An oil collecting vessel with a filter is available. The valve is of the mechanical type and it does not require electrical connection.
The heat exchangers of the 18 and 21 litre gas version are in the recess for maximum power within the shortest amount of time.
Designed for high productivity.
Digital version allows you to set a single-degree ignition differential to have a more reactive machine.
There is a melting function that provides a preheating and maintenance temperature for the machine to be ready.



Versione elettrica con resistenza a bandiera e controllo digitale ultra-preciso

Electric version with resistor flag and digital control ultra-precise



Vasche da 13 a 21 L: massima potenza, zero attese, alta produttività

13 to 21 L tanks: maximum power, zero waiting, high productivity



Scambiatori in vasca per performance immediate: ideale per l'alta produttività

Tank heat exchangers for immediate performance: ideal for high productivity

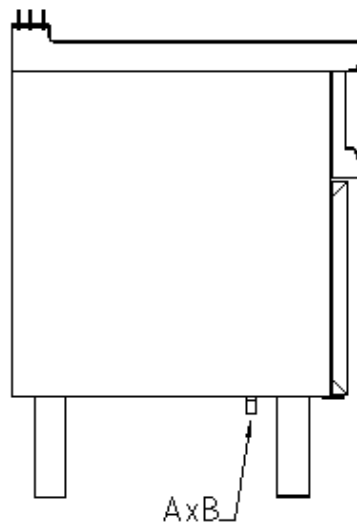
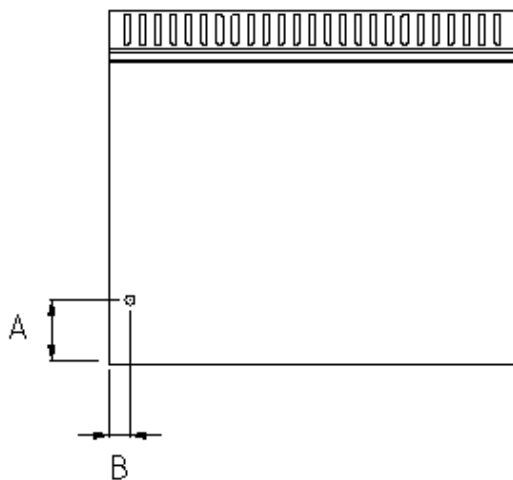

Schema per risalire alla predisposizione delle utenze

FRIGGITRICE A GAS SU BASE ARMADIATA 2 VASCHE GAS FRYER ON CUPBOARD BASE 2 TANKS

CODICE CODE	ALIMENTAZIONE M 1 / 2" - A x B POWER
7CFFG2SI	215 X 20
9CFFG2SI	215 X 20
7CFFG2D (digitale)	215 X 20
9CFFG2D (digitale)	215 X 20

CODICE CODE	DIMENSIONI (mm.) L X P X H DIMENSIONS (mm.)	KW	KW TOT	CAPACITA' CAPACITY
7CFFG2SI	800x700x900	15,5x2	31	18x2 L
9CFFG2SI	800x900x900	15,5x2	31	18x2 L
7CFFG2D (digitale)	800x700x900	15,5x2	31	18x2 L
9CFFG2D (digitale)	800x900x900	15,5x2	31	18x2 L

ACCESSORI A RICHIESTA / OPTIONAL ACCESSORIES

CODICE CODE	DESCRIZIONE DESCRIPTION
541090	TERMOMETRO ANALOGICO SINGOLO (1 PER VASCA)
44010023	BACINELLA TRASPORTO OLIO SERIE 700/900 240x510x140 OIL COLLECTION TRAY SERIES 700/900 240X510X140
44010024	FILTRO OLIO SERIE 700/900 / OIL FILTER SERIES 700/900
CFC404	CESTELLO PICCOLO 340X150X110 VASCA 18 LT SMALL BASKET 340X150X110 TANK 18 LT
CFC405	CESTELLO GRANDE 340X300X110 VASCA 18 LT BIG BASKET 340X300X110 TANK 18 LT

CON SCAMBIATORE ALL'INTERNO DELLA VASCA / ALL VERSION WITH INTERNAL TANK EXCHANGER
1 CESTELLO COMPRESO PER OGNI VASCA / 1 BASKET INCLUDED EACH TANK
1 BACINELLA TRASPORTO OLIO + FILTRO COMPRESA PER MACCHINA /
1 OIL COLLECTION TRAY + FILTER INCLUDED EACH MACHINE